

JKS-Series Dimensions

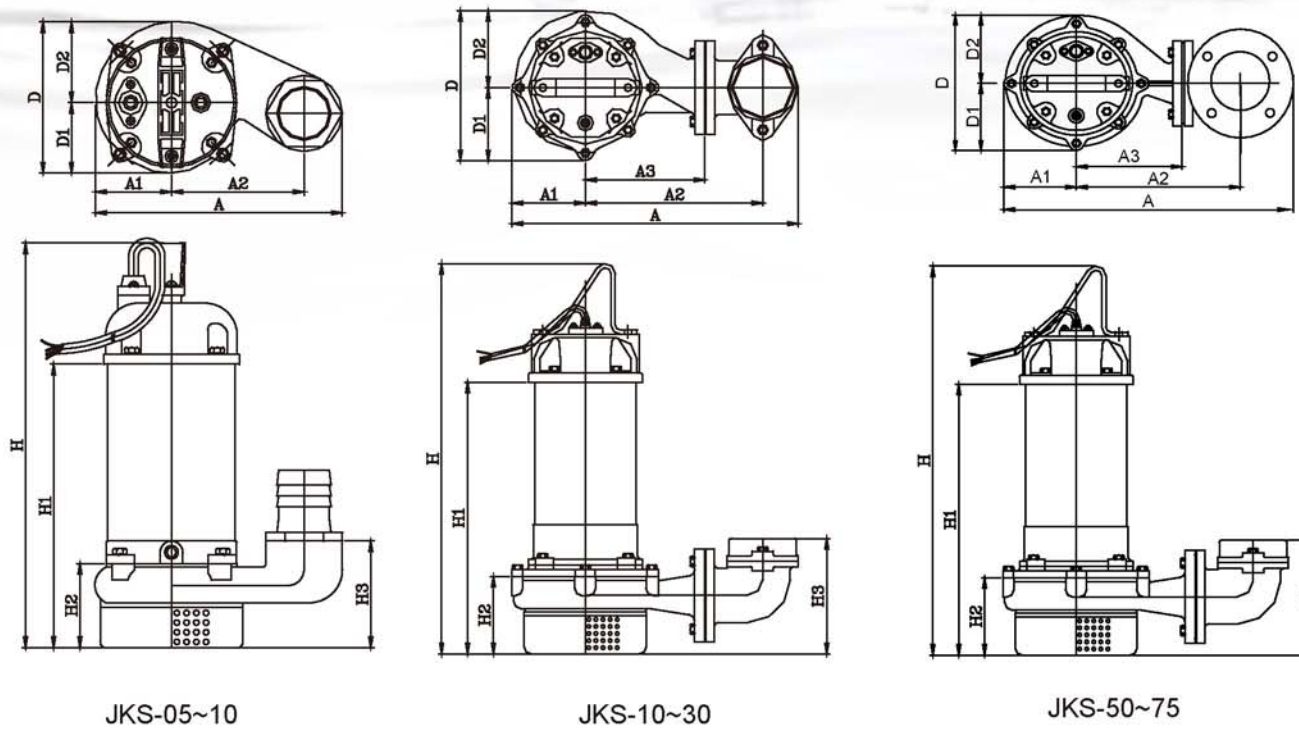

Dimensions (mm)											
Type	A	A1	A2	A3	D	D1	D2	H	H1	H2	H3
JKS-05	229	70	123	NA	141	66	75	350	250	79	100
JKS-10	229	70	123	NA	141	66	75	380	285	79	100
* JKS-10	325	80	192	110	165	75	90	398	273	97	147
JKS-20	403	103	250	168	212	103	109	555	385	110	163
JKS-30	403	103	250	168	212	103	109	575	405	110	163
JKS-50	466	110	264	176	227	110	117	605	440	132	220
JKS-75	466	110	264	176	227	110	117	645	480	132	220

» Note1 : Automatic models are available in single-phase versions(0.05~1HP) and in three-phase versions(0.5~2HP).
 » Note2 : Q.D.C.(Quick Discharge Connection) is available only for Elbow type.
 » Note3 : *JKS-10 is Elbow Type

JKS
SERIES 50HZ
Submersible Effluent Pump



JKS SERIES 50HZ

Submersible Effluent Pump

Feature

- / Compact Design / light weight
- / With High Efficiency Impeller
- / Double Mechanical Seals
- / Reliable Shaft sealing
- / Automatic Operation (Optional)

Application

- / Light duty / basement drainage
- / Rainwater effluent
- / Accumulated water drainage



JKS-20

JKS-05



High Efficiency Impeller

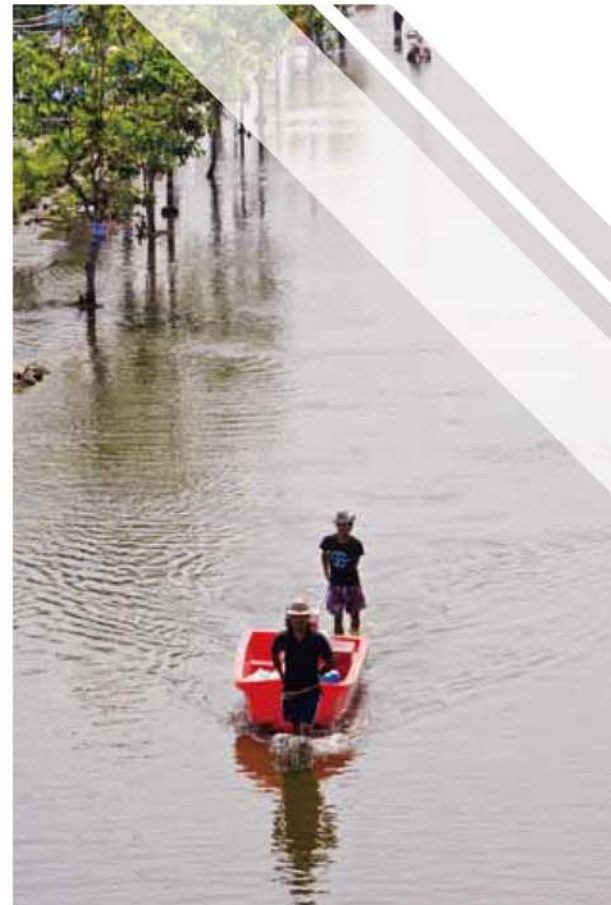

Specifications

Liquid Temperature		0~40°C (32~104°F)
Submersible depth		10M
Motor Part	Frequency	50Hz
	Pole	2 Pole
	Type	Dry Motor
	Insulation	Class E
	Protection	IP 68
Pump Part	Protector	Auto-cut
	Bearing	Ball Type
	Mechanical seal	Dual. Mechanical Seal
	Impeller	Semi-Open

Performance Curve

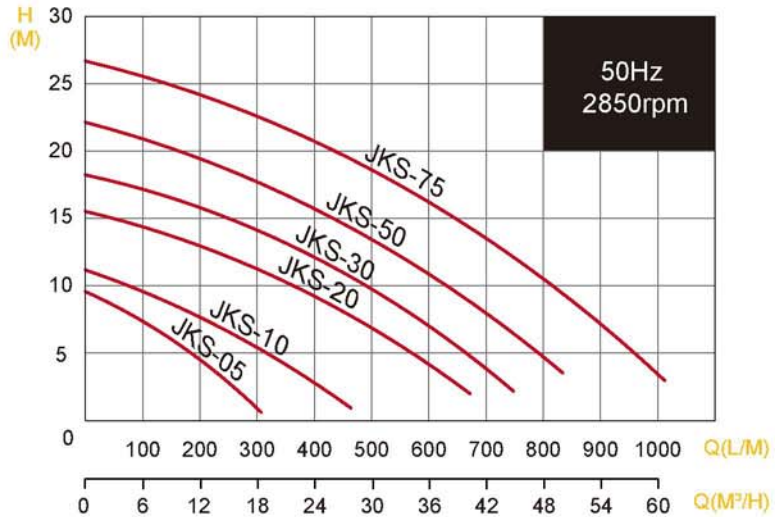

Parts and Material List

No	Part	Material
1	Cable	H07RN-F/SJTOW/STOW
2	Handle	Nylon 6 / SS41
3	Motor Cover	Nylon 66 / FC 200
4	Bracket	FC 200
5	Motor Housing	SUS 304
6	Shaft with Rotor	SUS 410
7	Oil Chamber	FC 200
8	Double Mech.Seal	Upper : CA / CE Lower : CA / CE(0.5~3HP);SIC / SIC(5~7.5HP)
9	Seal Housing	FC 200
10	Oil Seal	NBR
11	Impeller	FC 200
12	Pump Casing	FC 200
13	Protector	
15	Bearing	NTN
16	Strainer	SUS 304

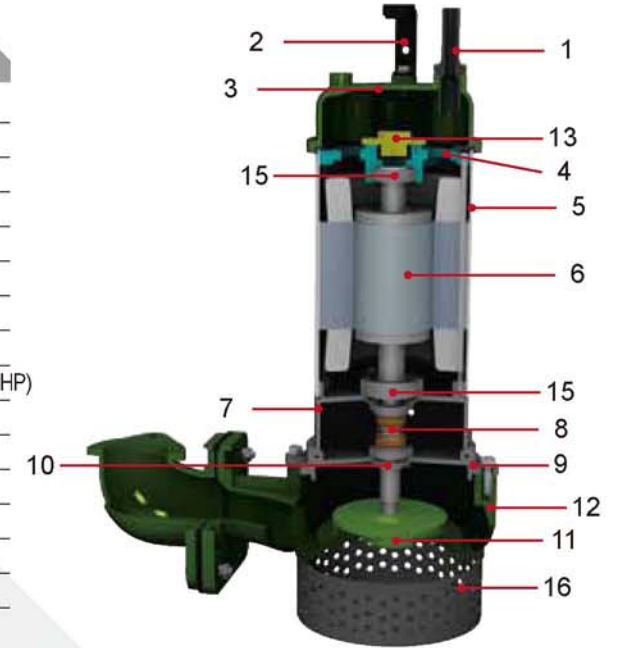

JKS-Series with QM

JKS with QM Q.D.C.

HP	KW	Discharge		Dimensions(mm)	
		Inch	mm	H	H1
2	1.5	2"(3")	50(80)	695	525
3	2.2	2"(3")	50(80)	715	545
5	3.7	3"(4")	80(100)	765	587
7.5	5.5	3"(4")	80(100)	805	627

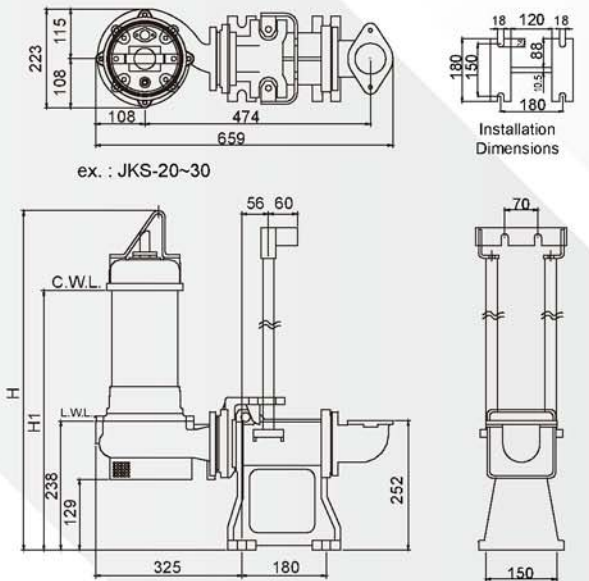

Selection Table

Type	Output		Discharge	F.L.A.		Rated		Maximum		Cable	Free Passage	Weight	Q.D.C.
	HP	KW		1ø 230V	3ø 400V	Head m	Cap. LPM	Head m	Cap. LPM				
JKS-05	0.5	0.37	2"	4	1.2	6	150	9.5	310	5	5	12.2	-
JKS-10	1	0.75	2"	6	2	8	150	11	450	5	5	19	-
JKS-20	2	1.5	2"(3")	11.3	3.5	10	360	15.5	680	5	5.5	35.7	QM-80
JKS-30	3	2.2	2"(3")	-	5.2	11	450	18.5	800	5	5.5	36.8	QM-80
JKS-50	5	3.7	3"(4")	-	8.6	8	700	22.5	950	10	5.5	56	QM-100
JKS-75	7.5	5.5	3"(4")	-	12	12	750	26.5	1100	10	5.5	62	QM-100

- » JKS-05 : Thread Type
- » JKS-10 : Thread Type / Elbow Type(2" or 3"/ Fit with Q.D.C. QM-80)
- » JKS-20~30 : Elbow Type
- » JKS-50~75 : Elbow Type